

Production equipment are an important asset within the energy sector. Control, separation and accurate measurement are key to understanding your process, inventory and bringing product to market.

At **Pembina Controls Inc.** our product line is suited to support your needs. Whether it a tank, separator, line heater, dehy or other production equipment you can look forward to quality instrumentation to meet your measurement needs.

FLOW MEASUREMENT:

- » Turbine meters (Threaded or Quicksert)
- » Totalizers (XP, I.S. and general area) with 4-20mA loop, pulse out, battery and optional Modbus
- » Ultrasonic meters
- » Electromagnetic meters
- » Differential meters



Badger Meter



Blancett®
Turbine Flow Meters



ModMAG®
Electromagnetic Flow Meters



Dynasonics®
Ultrasonic Flow Meters



Preso®
Differential Pressure Flow Meters

LEVEL MEASUREMENT:

- » Electric level switches
- » Snap acting pneumatic controls
- » Interface measurement
- » External Level cages
- » Radar, Guided Wave and Vibrating Level
- » Differential Level

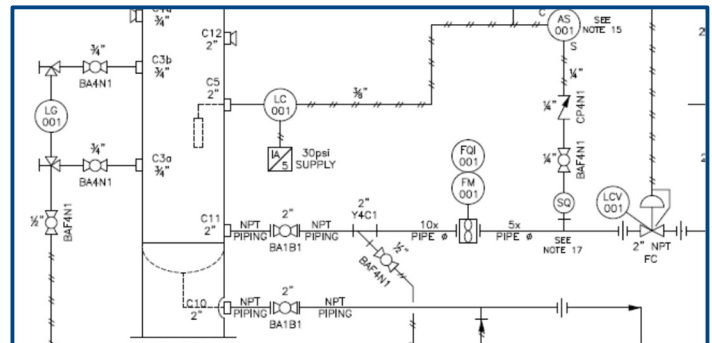

Distribution Center
9511 – 28th Avenue NW
Edmonton, AB T6N 0A3
780.432.6821



Order Desk & Customer Service
sales@pem-controls.com
1.877.736.2462
www.pem-controls.com

PRESSURE & TEMPERATURE MEASUREMENT:

- » Pressure transmitters & transducers
- » Pressure switches
- » Pressure and temperature indicator gauges
- » RTD's and blind temperature transmitters
- » 2, 3 and 5 valve manifolds
- » Block and bleed valves
- » Needle valves



AND MUCH MORE:

- » Microvalves
- » Solar/Electric Chemical Pumps
- » Solar/Electric Heat Trace Pumps
- » Water Cut Monitors
- » Diaphragm Seals
- » Instrument Shrouds

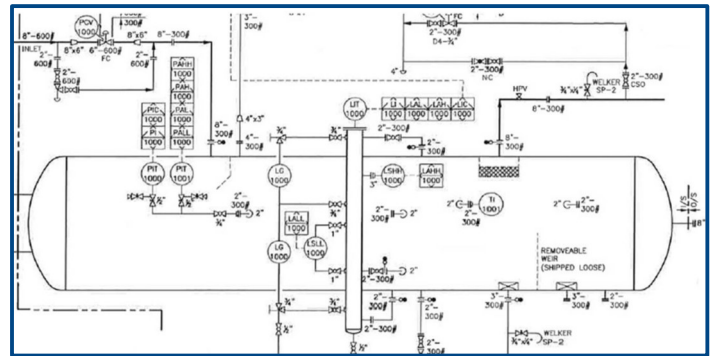

Distribution Center
9511 – 28th Avenue NW
Edmonton, AB T6N 0A3
780.432.6821



Order Desk & Customer Service
sales@pem-controls.com
1.877.736.2462
www.pem-controls.com