



Turbine Flow Meter

QuikSert® Explosion-Proof



User Manual

CONTENTS

Scope of This Manual	4
Unpacking and Inspection	4
Safety	4
Terminology and Symbols	4
Important	4
Introduction	5
Operating Principle	5
Installation	7
Operational Startup	9
Troubleshooting Guide	10
Specifications	11
Pressure Rating	11
Meter Parts	12
Part Number Information (Pickup Not Included)	13
Flow Range Chart	13
Strainer Recommendations	14
Repair Kit Information	14

SCOPE OF THIS MANUAL

This manual is intended to help you get the QuikSert turbine flow meter up and running quickly.

IMPORTANT

Read this manual carefully before attempting any installation or operation. Keep the manual accessible for future reference.

UNPACKING AND INSPECTION

Upon opening the shipping container, visually inspect the product and applicable accessories for any physical damage such as scratches, loose or broken parts, or any other sign of damage that may have occurred during shipment.

NOTE: If damage is found, request an inspection by the carrier's agent within 48 hours of delivery and file a claim with the carrier. A claim for equipment damage in transit is the sole responsibility of the purchaser.

SAFETY

Terminology and Symbols



Indicates a hazardous situation, which, if not avoided, *will* result in death or serious personal injury.



Indicates a hazardous situation, which, if not avoided, *could* result in severe personal injury or death.



Indicates a hazardous situation, which, if not avoided, *could* result in minor or moderate personal injury or damage to property.

IMPORTANT

Not following instructions properly may impair safety of equipment and/or personnel.

INTRODUCTION

The QuikSert® explosion-proof turbine flow meter was developed for liquid applications where accuracy and dependability are of concern to the operator. The QuikSert stainless steel body incorporates a helical turbine with tungsten carbide shaft and bearings. QuikSert Explosion proof turbines also have a welded pickup hub to eliminate any potential leak path for gases, reducing the chances of explosion. These characteristics provide an efficient, long service life and a cost-effective solution for your measurement requirements.

Simple in design and construction, QuikSert uses modified upstream and downstream flow straighteners for a high degree of flow accuracy. Its between-the-flange design eliminates the need for mating flanges, requiring less space in the flow line, lowering costs and providing easy, one-man installation.

The meter produces a sine wave signal proportional to its volumetric flow rate. With optional Pembina Controls electronics, QuikSert provides local flow rate and volume totalization and will interface with most instruments, PLCs and computers.

OPERATING PRINCIPLE

Fluid entering the meter passes through the inlet flow straightener which reduces its turbulent flow pattern and improves the fluid's velocity profile. Fluid then passes through the turbine, causing it to rotate at a speed proportional to the fluid velocity. As each turbine blade passes through the magnetic field, the blade generates an AC voltage pulse in the pickup coil at the base of the magnetic pickup (see *Figure 1*). These pulses produce an output frequency proportional to the volumetric flow through the meter. The output frequency represents flow rate and/or totalization of fluid passing through the turbine flow meter.

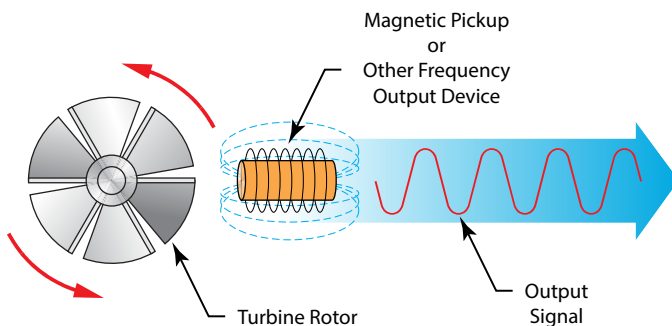

Figure 1: Schematic illustration of electric signal generated by rotor movement



Figure 2: Etching

NOTE: For easy reference, the meter specifications that include part number, serial number, maximum working pressure, and minimum and maximum operating temperature are etched or imprinted on the meter body.

INSTALLATION

Prior to installation, the flow meter should be checked internally for foreign material and to ensure the turbine rotor spins freely. Fluid lines should also be checked and cleared of all debris.

The flow meter must be installed with the flow arrow, etched on the exterior of the meter body, pointing in the direction of fluid flow. Though the meter is designed to function in any position, it is recommended, where possible, to install horizontally with the conduit adapter facing upward. Thread a magnetic pickup (Pembina Controls model BP111109 or equivalent) into the conduit adapter completely finger tight without forcing. Secure with a lock nut if supplied. Install conduit or other fittings suitable for the installation area onto the conduit adapter hub on the flow meter.

The liquid being measured should be free of any large particles that may obstruct rotation of the rotor. If particles are present, a mesh strainer should be installed upstream before operation of the flow meter.

The preferred plumbing setup is one containing a bypass line (*Figure 3 on page 7*) that allows meter inspection and repair without interrupting flow. If a bypass line is not used, it is important that all control valves be located downstream of the flow meter (*Figure 4 on page 8*).

⚠ WARNING

PRESSURE IN EXCESS OF ALLOWABLE RATING MAY CAUSE THE HOUSING TO BURST AND CAUSE SERIOUS PERSONAL INJURY.

⚠ CAUTION

DAMAGE CAN BE CAUSED BY STRIKING AN EMPTY METER WITH A HIGH VELOCITY FLOW STREAM.

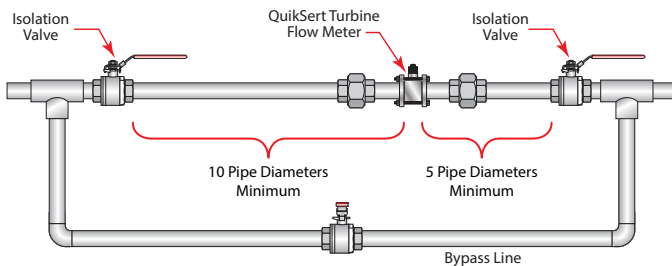

Figure 3: Meter installation using a bypass line

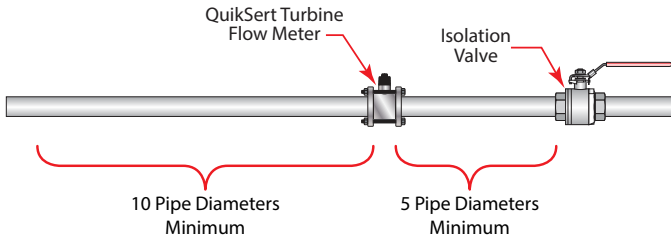

Figure 4: Meter installation without using a bypass line

This is true with any restriction in the flow line that may cause the liquid to flash. If necessary, air eliminators should be installed to ensure that the meter is not incorrectly measuring entrained air or gas.

It is recommended that a minimum length, equal to ten (10) pipe diameters of straight pipe, be installed on the upstream side and five (5) diameters on the downstream side of the flow meter. Otherwise, meter accuracy may be affected. Piping should be the same size as the meter bore or threaded port size.

Do not locate the flow meter or connection cable close to electric motors, transformers, sparking devices, high voltage lines, or place connecting cable in conduit with wires furnishing power for such devices. These devices can induce false signals in the flow meter coil or cable, causing the meter to read inaccurately.

If problems arise with the flow meter and monitor, consult *"Part Number Information (Pickup Not Included)"* on page 13. If further problems arise, consult the factory.

If the internal components of the turbine flow meter are damaged beyond repair, turbine meter repair kits are available. Information pertaining to the turbine meter repair kits is referenced in *"Repair Kit Information"* on page 14.

OPERATIONAL STARTUP

The following steps should be followed when installing and starting the meter.

⚠ WARNING

MAKE SURE THAT FLUID FLOW HAS BEEN SHUT OFF AND PRESSURE IN THE LINE RELEASED BEFORE ATTEMPTING TO INSTALL THE METER IN AN EXISTING SYSTEM.

1. After meter installation, close the isolation valves and open the bypass valve. Flow liquid through the bypass valve for sufficient time to eliminate any air or gas in the flow line.

⚠ CAUTION

HIGH VELOCITY AIR OR GAS MAY DAMAGE THE INTERNAL COMPONENTS OF THE METER.

2. Open upstream isolating valve slowly to eliminate hydraulic shock while charging the meter with the liquid. Open the valve to full open.
3. Open downstream isolating valve to permit meter to operate.
4. Close the bypass valve to a full closed position.
5. Adjust the downstream valve to provide the required flow rate through the meter.

NOTE: The downstream valve may be used as a control valve.

TROUBLESHOOTING GUIDE

Trouble	Possible Cause	Remedy
Meter indicates higher than actual flow rate	<ul style="list-style-type: none"> • Cavitation • Debris on rotor support • Build up of foreign material on meter bore • Gas in liquid 	<ul style="list-style-type: none"> • Increase back pressure • Clean meter • Clean meter • Install gas eliminator ahead of meter
Meter indicates lower than actual flow rate	<ul style="list-style-type: none"> • Debris on rotor • Worn bearing • Viscosity higher than calibrated 	<ul style="list-style-type: none"> • Clean meter and add filter • Clean meter and add filter • Recalibrate monitor
Erratic system indication, meter alone works well (remote monitor application only)	Ground loop in shielding	Ground shield one place only. Look for internal electronic instrument ground. Reroute cables away from electrical noise
Indicator shows flow when shut off	Mechanical vibration causes rotor to oscillate without turning	Isolate meter
No flow indication Full or partial open position	Fluid shock, full flow into dry meter or impact caused bearing separation or broken rotor shaft	Rebuild meter with repair kit and recalibrate monitor. Move to location where meter is full on startup or add downstream flow control valve
Erratic indication at low flow, good indication at high flow	Rotor has foreign material wrapped around it	Clean meter and add filter
No flow indication	Faulty pickup	Replace pickup
System works perfect, except indicates lower flow over entire range	Bypass flow, leak	Repair or replace bypass valves, or faulty solenoid valves
Meter indicating high flow, upstream piping at meter smaller than meter bore	Fluid jet impingement on rotor	Change piping
Opposite effects of above	Viscosity lower than calibrated	Change temperature, change fluid or recalibrate meter

SPECIFICATIONS

Materials of Construction	Body	316/316L stainless steel
	Rotor	CD4MCu stainless steel
	Bearings	Tungsten carbide
	Rotor Shaft	Tungsten carbide
	Rotor Support	316L
Operating Temperature	-150...350° F (-101...177° C) standard Temperatures to 450° F (232° C) with high-temp pickup, consult factory for details The standard meter should not be subjected to temperatures above 350° F (177° C), or below -150° F (-101° C) or the freezing point of the metered liquid.	
Pressure Rating	See "Pressure Rating" below	
End Connections	Wafer-Style ASME/ANSI B16.5-1996	
Turndown Ratio	—	
Accuracy	± 1.0% of reading for 7/8 in. and larger meters. ± 1.0% of reading over the upper 70% of the measuring range for 3/8, 1/2, and 3/4 in. meters.	
Repeatability	± 0.1%	
Calibration	Water; NIST Traceable Calibration, Certificate available, consult factory for details	
Pickup	BP111109, BP220111, BP220210, B220243, B111126	
Conformance	NACE MR0175/ISO 15156	
Pressure Standards/ Approvals	Canadian Registration Number (CRN), PED 2014/68/EU, Group 1, Category II	
Pulsation and Vibration	Severe pulsation and mechanical vibration will affect accuracy and shorten the life of the meter.	
Certifications	Class I Div. I Groups C,D Complies to UL1203 and CSA 22.2 No. 30 Met Labs File No. E112860	

Pressure Rating

The pressure rating of the meter is dependent upon the class of ANSI flanges between which the meter is to be mounted. The pressure rating chart below is based on Carbon Steel at 100° F (37.8° C).

Flange Class (ANSI)	150#	300#	600#	900#	1500#
Working Pressure (psi)	285	740	1480	2220	3705
Working Pressure (bar)	20	51	102	153	256
Working Pressure (MPa)	1.97	5.10	10.20	15.31	25.55
¹ Test Pressure (psi)	427.5	1110	2220	3330	5557.5
¹ Test Pressure (MPa)	2.95	7.65	15.31	22.98	38.32

¹ Test pressure based on 1.5 safety factor

METER PARTS

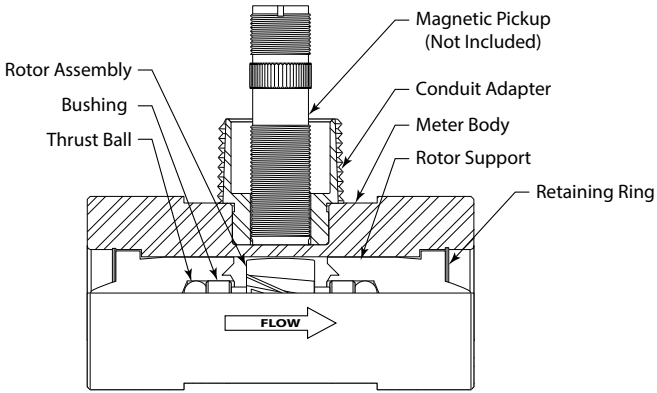

Figure 5: Typical cross-section of models BP131C-038...BP131C-100

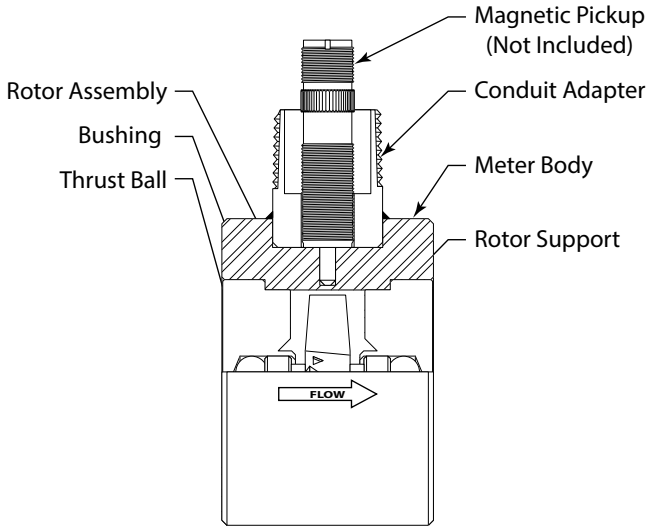

Figure 6: Typical cross-section of models BP132C-050...BP139C-900

PART NUMBER INFORMATION (PICKUP NOT INCLUDED)

Part Number	Meter Bore Size × Line Size (in.)	PED Compliant	Flow Range	Strainer Mesh	Approx. K-Factor pulses/ US gal	Weight	Max. Pressure Drop (psi)
BP131C-038	3/8 × 1	Coming soon	See "Flow Range Chart" below	60	18,000	—	3.75
BP131C-050	1/2 × 1	Coming soon		60	13,000	—	6.5
BP131C-075	3/4 × 1	Coming soon		60	3300	—	18
BP131C-088	7/8 × 1	Coming soon		60	3100	—	20
BP131C-100	1 × 1	Coming soon		60	870	—	20
BP132C-050	1/2 × 2	Coming soon		60	13,000	—	12
BP132C-075	3/4 × 2	Coming soon		60	3300	—	18
BP132C-088	7/8 × 2	Coming soon		60	3100	—	20
BP132C-100	1 × 2	Coming soon		40	870	—	20
BP132C-150	1-1/2 × 2	Coming soon		20	330	—	16
BP132C-200	2 × 2	Yes		20	52	—	9
BP132C-250	2 × 3	Yes		10	52	—	10
BP133C-300	3 × 3	Yes		10	57	—	10
BP133C-380	3 × 3	Yes		10	57	—	10
BP134C-400	4 × 4	Yes		10	29	—	10
BP136C-600	6 × 6	Coming soon		4	7	—	10
BP138C-800	8 × 8	Coming soon		4	3	—	10
BP139C-900	10 × 10	Coming soon		4	1.6	—	10

Flow Range Chart

Part Number	Flow Ranges		
	gpm (lpm)	bpd	m ³ /d
BP131C-038	0.60...3.00 (2.27...11.36)	20...100	3.3...16
BP131C-050	0.75...7.50 (2.84...28.39)	25...250	4.1...41
BP131C-075	2.00...15.00 (7.57...56.78)	68...515	10.9...81.75
BP131C-088	3.00...30.00 (11.36...113.56)	100...1000	16...160
BP131C-100	5.00...50.00 (18.93...189.27)	170...1700	27.25...272.5
BP132C-050	0.75...7.50 (2.84...28.39)	25...250	4.1...41
BP132C-075	2.00...15.00 (7.57...56.78)	68...515	10.9...81.75
BP132C-088	3.00...30.00 (11.36...113.56)	100...1000	16...160
BP132C-100	5.00...50.00 (18.93...189.27)	170...1700	27.25...272.5
BP132C-150	15.00...180.00 (56.78...681.37)	515...6000	82...981
BP132C-200	40.00...400.00 (151.42...1514.16)	1300...13,000	218...2180
BP132C-250	40.00...400.00 (151.42...1514.16)	1300...13,000	218...2180
BP133C-300	60.00...600.00 (227.12...2271.25)	2100...21,000	327...3270
BP133C-380	80.00...800.00 (302...3028)	2750...27,500	430...4300
BP134C-400	100.00...1200.00 (378.54...4542.49)	3400...41,000	545...6540
BP136C-600	200.00...2500.00 (757.08...9463.53)	6800...86,000	1,090...13,626
BP138C-800	350.00...3500.00 (1324.89...13248.94)	12,000...120,000	1,363...19,076
BP139C-900	500.00...5000.00 (1892.71...18927.06)	17,000...171,000	2,725...27,252

NOTE: All models available as Non-Calibrated (NCC). NCC models are without NIST certified calibration. Nominal K-factor provided.
Example: BP132C-038-NCC

Strainer Recommendations

Part Number	Strainer Mesh	Clearance (in.)	Filter Size
BP131C-038	60	0.0092	260 Micron
BP131C-050	60	0.0092	260 Micron
BP131C-075	60	0.0092	260 Micron
BP131C-088	60	0.0092	260 Micron
BP131C-100	60	0.0092	260 Micron
BP132C-050	60	0.0092	260 Micron
BP132C-075	60	0.0092	260 Micron
BP132C-088	60	0.0092	260 Micron
BP132C-100	40	0.0150	400 Micron
BP132C-150	20	0.0340	0.86
BP132C-200	20	0.0650	0.86
BP132C-250	10	0.0900	1.6
BP133C-300	10	0.0900	1.6
BP133C-380	10	0.0900	1.6
BP134C-400	10	0.0650	1.6
BP136C-600	4	0.1875	4.8
BP138C-800	4	0.0900	4.8
BP139C-900	4	0.0900	4.8

Repair Kit Information

Repair Kit Fits Meter Part Number	Repair Kit Part Number	Max. Pressure Drop	Dimensions Diameter x Length in. (mm)
BP131C-038	BP251-102	3.75 psi	2 × 4 (50.4 × 101.6)
BP131C-050	BP251-105	6.5 psi	2 × 4 (50.4 × 101.6)
BP131C-075	BP251-108	18 psi	2 × 4 (50.4 × 101.6)
BP131C-088	BP251-109	20 psi	2 × 4 (50.4 × 101.6)
BP131C-100	BP251-112	20 psi	2 × 4 (50.4 × 101.6)
BP132C-050	BP253-205	12 psi	3.62 × 2.5 (91.9 × 63.5)
BP132C-075	BP253-208	18 psi	3.62 × 2.5 (91.9 × 63.5)
BP132C-088	BP253-209	20 psi	3.62 × 2.5 (91.9 × 63.5)
BP132C-100	BP253-212	20 psi	3.62 × 2.5 (91.9 × 63.5)
BP132C-150	BP253-216	16 psi	3.62 × 2.5 (91.9 × 63.5)
BP132C-200	BP253-220	9 psi	3.62 × 2.5 (91.9 × 63.5)
BP132C-250	BP253-220	10 psi	5 × 4.25 (127 × 108)
BP133C-300	BP253-330	10 psi	5 × 4.25 (127 × 108)
BP133C-380	BP253-330	10 psi	5 × 4.25 (127 × 108)
BP134C-400	BP253-440	10 psi	6.18 × 5 (157 × 127)
BP136C-600	BP253-660	10 psi	8.5 × 5.75 (215.9 × 146.1)
BP138C-800	BP253-880	10 psi	10.62 × 6.25 (269.7 × 158.8)
BP139C-900	BP253-990	10 psi	12.75 × 6.75 (323.8 × 171.4)
All Meter Sizes	BP111109	—	Standard Magnetic Pickup

NOTE: For NCC (no calibration) repair kit, add 'NCC' at the end of the part number.
Example: BP251-102-NCC

The Pembina Explosion Proof Quiksert is proprietary to Pembina Controls Inc. and a private labeled Blancett product. Blancett is a registered trademark of Badger Meter, Inc. Other trademarks appearing in this document are the property of their respective entities. Due to continuous research, product improvements and enhancements, Badger Meter reserves the right to change product or system specifications without notice, except to the extent an outstanding contractual obligation exists. © 2020 Badger Meter, Inc. All rights reserved.

Head Office and Distribution Center:

9511 – 28th Avenue NW | Edmonton, Alberta | T6N 0A3

Phone: 780.432.6821 | Fax: 780.432.6867 | Email: sales@pem-controls.com

Toll Free (USA & Canada): 1.877.736.2462 | International: +01 780.432.6821

All Corporate names and trademarks appearing in this document are the property of their respective entities. © All rights reserved. 2021 Pembina Controls Inc.

www.pem-controls.com