

Presco®-Switch

Installation, Operation and Maintenance Procedures

For Assemblies With:
Base Housings of Type D or S
Switch Housings of Type F, FF, V, VV, FV or M
All Pressure Ranges

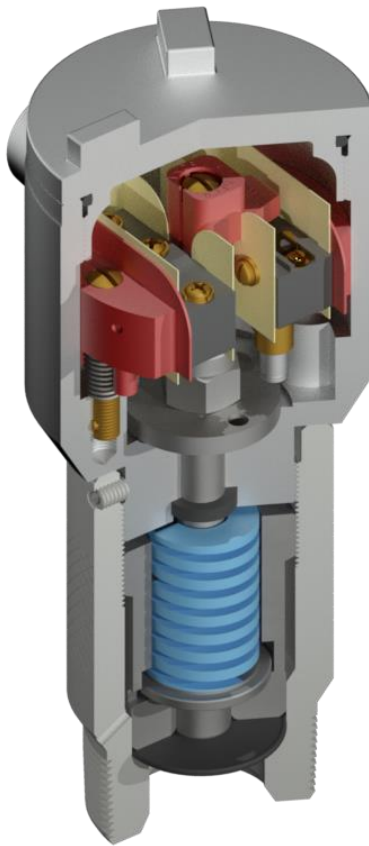

1.0 Installation:

Installation is to be done by qualified personnel only. It is recommended to install a Presco-Isolator Valve or other isolation valve before the Presco-Switch for ease of calibration, maintenance and removal.

1.1 Presco-Isolator Valve, 2" Threaded:

1. Apply a high-quality PTFE based sealant (i.e. Jet-Lube TF-15, V-2 or similar) to the threads before installation to prevent galling and corrosion. Teflon tape should only be used if required.
2. Install the isolator valve in the vertical-up orientation, using the wrench flats only for tightening the valve into the line. Do not use a pipe wrench on the body as this can damage the valve.
3. Install bleed/test valves, gauges or plugs required into the two (2) 1/2" NPT instrument ports.
4. Install the Presco-Switch as per 1.2 below

1.2 Presco-Switch, All Models:

1. Apply a high-quality PTFE based sealant (i.e. Jet-Lube TF-15, V-2 or similar) to the threads before installation to prevent galling and corrosion. Teflon tape should only be used if required, ensuring tape does not enter the internal wetted parts.
2. Install the Presco-Switch in the vertical-up orientation, using a pipe wrench on the knurled section of the lower base housing. **Do not apply torque to the upper switch housing section** or to the non-knurled sections of the base housing as damage will occur.
3. Complete the wiring of the microswitches using the appropriate wiring diagram(s) found in Section 2.0 and as per the electrical code in your area. A customer supplied conduit seal is required on the hub of the switch housing. If using a Presco-Cable assembly, this seal is provided.
4. Before closing the switch housing cover, check the interior of the switch housing, around the microswitch and reset tripper assemblies installed for wire, insulation or other materials that can interfere with the operation of the microswitch(s) and reset tripper.
5. Before applying pressure to the isolator valve and Presco-Switch, ensure the threaded connections are tight. If hydro-testing prior to operation, do not exceed the upper spring range of the Presco-Switch or Maximum Working Pressure of the Isolator Valve (whichever is lower).

2.0 Operation:

When pressure is applied to the base of the Presco-Switch, the diaphragm (type D) or plunger (type S) moves a piston rod. Resistance is provided by a pressure spring located in the base. When the set pressure is reached, the trip plate attached to the piston rod will trip the microswitch opening or closing the circuit.

For models with fixed differential, the switch will automatically reset once pressure drops below the trip point. See sections 2.1 and 3.1 below.

For models with variable differential, the switch will automatically reset once pressure drops below the differential tripper set point. See sections 2.2 and 3.2 below.

For models with manual reset, the switch will not reset until an operator presses the manual reset button. See sections 2.3 and 3.3 below.

2.1 Type F and FF Microswitch Operation (Fixed Differential):

The control setting is adjustable within the pressure range of the adjusting spring. Differential is fixed within the tolerance of the switch. Approximately +/- 4%. Wiring is either normally open or normally closed as illustrated in 2.5 fixed differential.

2.2 Type V and VV Microswitch Operation (Variable Differential):

The control setting is with a variable differential pressure between high and low settings. Wiring may either open or close a circuit when pressure falls below or rises above operating pressure. When pressure returns to normal operating range, the circuit is returned to it's normally open or normally closed state. Wiring is as illustrated in 2.5 variable differential.

2.3 Type M Microswitch Operation (Manual Reset):

The control circuit opens or closes when pressure reaches the set point. The switch maintains a tripped state until pressure is below the set point and the manual pushbutton is pressed. Wiring is as illustrated in 2.5 Manual Reset.

2.4 Type FV Microswitch Operation (Fixed/Variable Differential):

Dual control settings are independently adjustable with (1) fixed differential pressure switch and (1) variable differential pressure switch. Refer to 2.1 for wiring of the fixed switch and 2.2 for wiring of the variable switch.

2.5 Circuit Diagrams:

Fixed Differential Circuit (Automatic Reset) – Type F, FF or FV:

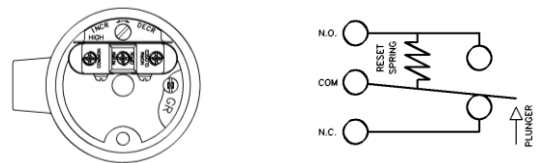

Variable Differential Circuit (Automatic Reset) – Type V, VV or FV:

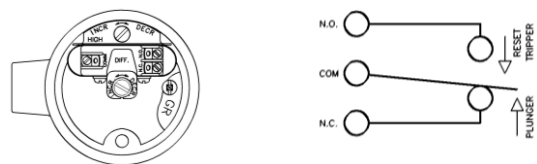

Manual Reset Circuit – Type M:

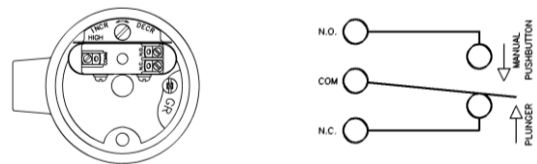

3.0 Microswitch Calibration:

Presco-Switch assemblies are not shipped pre-calibrated. The installer must setup and calibrate the pressure settings for the operation required. Calibration is to be done by qualified personnel only. Assemblies can be adjusted as follows:

Warning! Prior to opening the switch housing cover, ensure the area around the Presco-switch is non-hazardous, de-energize and lockout.

Warning! Pressurized fluids released to atmosphere can contain substances that will injure or cause death if exposed.

1. Close the isolator valve and bleed pressure from base.
2. Connect calibration equipment to the test ports on the isolator valve.
3. Pressurize switch base to required setting and refer to either 3.1, 3.2 or 3.3 below for setting the microswitches.

3.1 Fixed Differential – Type F, FF or FV:

1. To obtain an accurate setting, it is important that no downward pressure is exerted on the adjusting screws while turning them.
2. This circuit can only have a single pressure setting.
3. Turn the pressure adjusting screw clockwise to decrease the setting and counter-clockwise to increase setting.

3.2 Variable Differential – Type V, VV or FV:

1. To obtain an accurate setting, it is important that no downward pressure is exerted on the adjusting screws while turning them.
2. This circuit has a high-pressure and a reset pressure setting (differential).
3. Turn the high-pressure adjusting screw clockwise to decrease the setting and counter-clockwise to increase setting.
4. Turn the differential adjusting screw (tripper arm) clockwise to decrease the setting and counter-clockwise to increase the setting.

3.3 Manual Reset – Type M:

1. To obtain an accurate setting, it is important that no downward pressure is exerted on the adjusting screws while turning them.
2. The circuit has a single pressure setting only and is maintained after being tripped until the reset button is pressed.
3. Turn the pressure adjusting screw clockwise to decrease the setting and counter-clockwise to increase setting.

After setting the switch according to 3.1, 3.2, and 3.3 above, repeat these steps three times to ensure the setting is repeatable. See 4.3 trouble shooting.

4.0 Maintenance:

The Presco-Switch should be cleaned, inspected and re-calibrated annually or as soon as a malfunction is suspected to maintain proper functioning of the Presco-Switch. If in a critical service application, the Presco-Switch should be tested every three months.

4.1 Precautions:

- Do not allow water or other liquids to enter the internals while cleaning as this may cause internal damage to the components.
- Do not use de-greasers or other cleansers that can damage the materials in the Presco-Switch. Including the insulation, microswitches, soft seals or wiring.

Warning! Prior to opening the switch housing cover, ensure the area around the Presco-switch is non-hazardous, de-energize and lockout.

Warning! Pressurized fluids released to atmosphere can contain substances that will injure or cause death if exposed.

4.2 Maintenance & Repair:

Maintenance and Repairs are to be done by qualified E&I professionals only, using Presco-Switch OEM parts.

1. Close the isolator valve on the Presco-Switch and depressurize according to your company procedures.
2. Only if required, remove the Presco-Switch from the line. Refer to section 1.0 Installation for more information.
3. Wipe away any dirt and oil build up on the outside of the switch.
4. Confirm the Presco-switch is in good working order and there are no corroded or damaged parts that need replacement. Replace with Presco-Switch OEM parts if needed.
5. Check calibration of the microswitches. Adjust if necessary, according to the calibration procedure in section 3.0.
6. Check that there are no obstructions inside the switch housing that can prevent the microswitches from operating properly before closing the cover.
7. If the switch was removed from the line, re-install according to the Installation procedure in section 1.0 Installation.
8. Slowly open the isolator valve, returning line pressure to the bottom section of the switch.
9. Ensuring the area around the Presco-switch is non-hazardous, re-energize and return to normal service.

4.3 Troubleshooting

Fluid is seeping from the vent holes in the base	The primary pressure seals are leaking and need to be replaced The piston/plunger has corroded and requires replacement
There is no signal from the microswitch	Power to the switch is off There is a break in the wiring, check loop continuity Wires are connected to the wrong terminals. See section 2.0 for switch operation. Line pressure is outside of the trip point. See section 3.0 for calibration. Press the manual reset button (Type M only) to reset the microswitch Microswitch needs replacement
Switch trips at the wrong pressure	Check the calibration of the Presco-switch and re-calibrate according to section 3.0. Check for obstructions around the microswitches or reset tripper. See section 1.0.
Switch doesn't maintain a repeatable pressure setting	Pressure adjusting screw, spring or microswitch requires replacement Main pressure spring needs replacement There was downward pressure on the adjusting screws when calibrating. See section 3.0.

5.0 Presco-Switch Model Number Breakdown:

Base Arrangement Type:

- Type D – Diaphragm model for mildly sour and corrosive gas, crude oil and water service
- Type S – Plunger model for sour and corrosive gas, crude oil and water service

Switch Housing Arrangement Type:

- Type F – Single Fixed Differential Switch, 4approx. +/- 4% differential
- Type FF – Dual Fixed Differential Switch, with independent circuits
- Type FV – One Fixed Differential Switch, One Variable Differential Switch
- Type V – Single Variable Differential Switch, for high / low setting differential
- Type VV – Dual Variable Differential Switch, with independent circuits
- Type M – Single Switch, manually reset after trip

Spring Pressure Range Number:

- Spring Pressure Range Number is the maximum set pressure divided by 10 for all switches except Type-D with the 1.25" piston.
- See Table 2. Range numbers for Type-D with the 1.25" piston are 7, 15 and 20 in order from lowest to highest max pressure.

DFF – 100 (Diaphragm base with dual fixed differential switches, 100 – 1,000 psi spring range)

Table 1 – Pressure Sensing Base Housing Models and Dimensions:

Type	Design	Operating Conditions	Maximum Working Pressure	Overall Length mm (in)	Weight kg (lbs)
D	Hydrin® diaphragm pressure sensor with backup plunger	Standard oilfield and mildly sour and corrosive gas, crude oil and water service	1.25" Piston 1,380 kPa (200 psi)	Standard 225 (8.8)	3.4 (7.6)
			0.63" Piston 20,684 kPa (3,000 psi)	Reset(-M) 272 (10.7)	3.5 (7.8)
S	Lapped stainless steel plunger pressure sensor with energized Teflon® seal	Standard oilfield and sour and corrosive gas, crude oil and water service	34,474 kPa (5,000 psi) All Models	Standard 236 (9.3)	3.9 (8.6)
				Reset(-M) 283 (11.2)	4.0 (8.8)

Table 2 – Presco-Switch Spring Chart:

Colour (diameter)	Part	Type D 1.25" Piston	Type D 0.63" Piston	Type S 0.87" Piston	Type S 0.63" Piston	Type S 0.38" Piston
Red (0.81")	750-00001	10 – 70 psi 69 – 483 kPa				
Green (1.0")	750-00013	15 – 90 psi 103 – 621 kPa	40 – 400 psi 276 – 2,758 kPa			
Blue (1.0")	750-00010	20 – 200 psi 138 – 1,379 kPa	60 – 600 psi 414 – 4,137 kPa			
White + Red (1.0")	750-10292		100 – 1,000 psi 689 – 6,895 kPa	40 – 300 psi 276 – 2,068 kPa		
Red (1.0")	750-00011		150 – 1,250 psi 1,034 – 8,618 kPa	50 – 400 psi 345 – 2,758 kPa	100 – 800 psi 689 – 5,516 kPa	275 – 2,000 psi 1,896 – 13,790 kPa
Yellow (1.0")	750-10269		300 – 1,500 psi 2,068 – 10,342 kPa	60 – 500 psi 414 – 3,447 kPa	125 – 1,000 psi 862 – 6,895 kPa	350 – 2,500 psi 2,413 – 17,237 kPa
Red (1.25")	750-00025		400 – 2,000 psi 2,758 – 13,789 kPa	70 – 600 psi 483 – 4,137 kPa	160 – 1,250 psi 1,103 – 8,618 kPa	425 – 3,000 psi 2,930 – 20,684 kPa
Yellow (1.25")	750-00008		500 – 2,500 psi 3,447 – 17,237 kPa	90 – 700 psi 621 – 4,826 kPa	200 – 1,500 psi 1,379 – 10,342 kPa	
Short Yellow	750-00028		600 – 3,000 psi 4,137 – 20,684 kPa			

5.1 General Specifications:

Repeatability	1% to 2% of adjustable range
Service	Standard and H ₂ S NACE MR0175 on Select Models
Electrical Temperature Rating	-58°F to 180°F (-50°C to 82°C)
Electrical Rating	5A – 125/250/480 VAC; 0.5A – 125VDC; 0.25A – 250VDC
Electrical Classification	CSA c/us Approved per C22.2/UL1203/UL508 Dual Seal Compliant per ANSI/ISA-12.27.01 requirements Class 1, Group D Hazardous Locations
Electrical Housing	Cast Aluminum; 3-1/2" OD
Electrical Connection	½"-14 NPT (female)
Pressure Connection	2" NPT (male); Zinc Electroplated High Strength Carbon Steel
Pressure Rating	Type D: 3,000psig (20,684kPag); -58°F to 180°F (-50°C to 82°C) Type S: 5,000psig (34,474kPag); -58°F to 180°F (-50°C to 82°C)
Canadian Registration Number	OF20302.213
Quality Program	AQP-5164

6.0 Parts Lists:

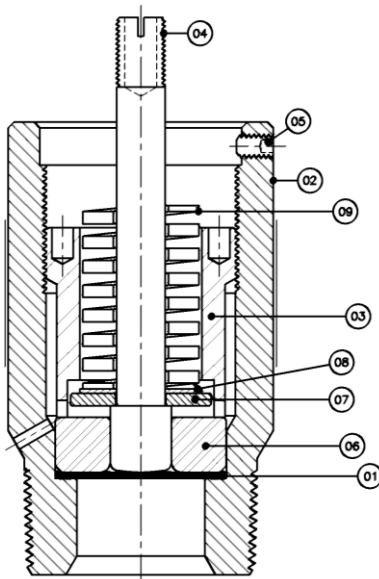

5/8" piston shown

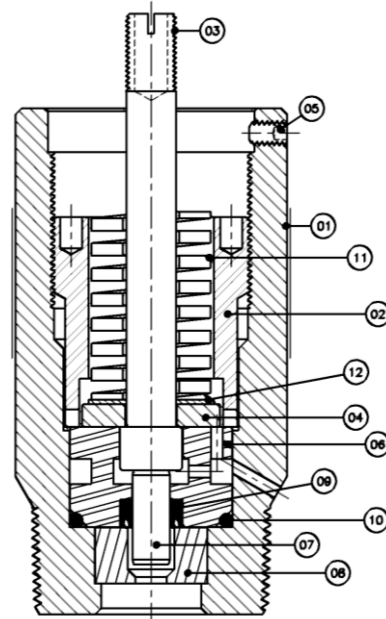

3/8" plunger shown

6.1 Type D Base Housing:

Item	Part No.	Description
△ 01	340-00087	Diaphragm, Hydrin®
02	397728	Type D Base (NACE)
03	340-00081	Piston Guide Sleeve, Type D
04	340-10017	Piston, Low Pressure, 1-1/4" dia.
	340-00084	Piston, Med Pressure, 5/8" dia.
05	700-00087	Set Screw
06	340-10022	Piston Guide, 1-1/4" dia. L.P.
	340-00079	Piston Guide, 5/8" dia. M.P.
07	340-00085	Spring Base Plate
08	Varies	Spacer, contact Pembina Controls
09	Varies	See Table 2 – Presco-Switch Spring Chart

6.3 Type S Base Housing:

Item	Part No.	Description
01	397700	Type S Base (NACE)
02	340-00177	Piston Guide Sleeve
03	340-00178	Piston Extension
04	340-00179	Spring Base Plate
05	700-00087	Set Screw
06	340-00193	Plunger Guide, 3/8" dia.
	340-00188	Plunger Guide, 5/8" dia.
	397701	Plunger Guide, 5/8" dia., NACE
	340-00180	Plunger Guide, 7/8" dia.
△ 07	340-00194	Plunger, 3/8" dia.
	340-00189	Plunger, 5/8" dia.
	397702	Plunger, 5/8" dia., NACE
08	340-00181	Plunger, 7/8" dia.
	340-00195	Plunger Retainer, 3/8" dia.
	340-00190	Plunger Retainer, 5/8" dia.
	397703	Plunger Retainer, 5/8" dia., NACE
△ 09	340-00182	Plunger Retainer, 7/8" dia.
	715-10084	Plunger Seal, 3/8" dia., Teflon®
	715-10085	Plunger Seal, 5/8" dia., Teflon®
	715-10086	Plunger Seal, 7/8" dia., Teflon®
△ 10	710-00050	O-Ring, Teflon®
11	Varies	See Table 2 – Presco-Switch Spring Chart
12	Varies	Spacer, contact Pembina Controls

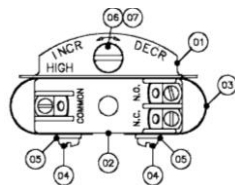

6.2 Type V and M Microswitch Assembly, Part 340-00050:

Item	Part No.	Description
01	340-00028	Switch Mounting Block
△ 02	730-10011	Microswitch, Variable
03	340-00029	Insulating Barrier
04	700-10763	Machine Screw
05	700-10292	Washer
06	340-00024	Adjusting Screw Assembly
07	750-00009	Switch Adjusting Spring

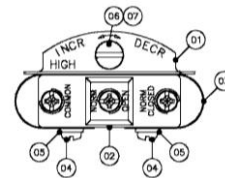

6.4 Type F Microswitch Assembly, Part 340-00218:

Item	Part No.	Description
01	340-00028	Switch Mounting Block
△ 02	730-10010	Microswitch, Fixed
03	340-00029	Insulating Barrier
04	700-10763	Machine Screw
05	700-10292	Washer
06	340-00024	Adjusting Screw Assembly
07	750-00009	Switch Adjusting Spring

△ Recommended Spare Part

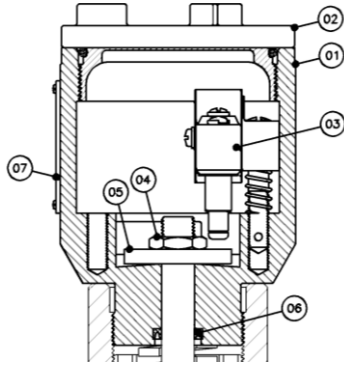

6.5 Type F Switch Housing, Part 340-00070:

Item	Part No.	Description
01	340-00071	Switch Housing
02	340-10216	Switch Housing Cover Assembly
03	340-00218	Fixed Microswitch Assembly
04	340-00031	Locknut
05	340-00023	Trip Plate
△ 06	715-10128	Seal Buna-N
07	742-10001	Nameplate
-	340-10166	Grounding Screw
-	340-00032	Drain Screw
-	700-00023	Roll Pin

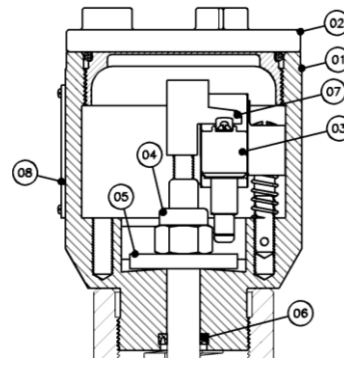

6.7 Type V Switch Housing, Part 340-00170:

Item	Part No.	Description
01	340-00071	Switch Housing
02	340-10216	Switch Housing Cover Assembly
03	340-00050	Variable Microswitch Assembly
04	340-00052	Extension Nut
05	340-00023	Trip Plate
△ 06	715-10128	Seal Buna-N
07	340-00053	Tripper Arm Assembly
08	742-10001	Nameplate
-	340-10166	Grounding Screw
-	340-00032	Drain Screw
-	700-00023	Roll Pin

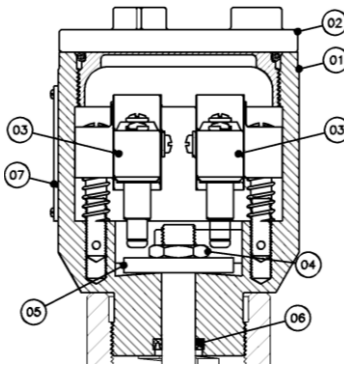

6.6 Type FF Switch Housing, Part 340-00113:

Item	Part No.	Description
01	340-00071	Switch Housing
02	340-10216	Switch Housing Cover Assembly
03	340-00218	Fixed Microswitch Assembly
04	340-00031	Locknut
05	340-00023	Trip Plate
△ 06	715-10128	Seal Buna-N
07	742-10001	Nameplate
-	340-10166	Grounding Screw
-	340-00032	Drain Screw
-	700-00023	Roll Pin

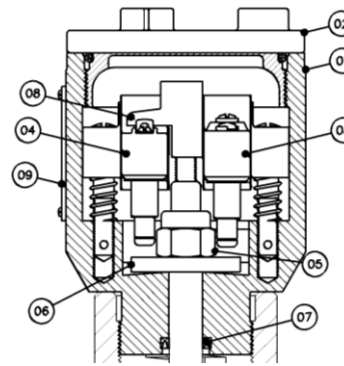

6.8 Type FV Switch Housing, Part 340-00174:

Item	Part No.	Description
01	340-00071	Switch Housing
02	340-10216	Switch Housing Cover Assembly
03	340-00218	Fixed Microswitch Assembly
04	340-00050	Variable Microswitch Assembly
05	340-00052	Extension Nut
06	340-00023	Trip Plate
△ 07	715-10128	Seal Buna-N
08	340-00053	Tripper Arm Assembly
09	742-10001	Nameplate
-	340-10166	Grounding Screw
-	340-00032	Drain Screw
-	700-00023	Roll Pin

△ Recommended Spare Part

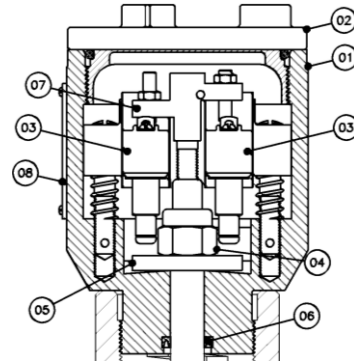
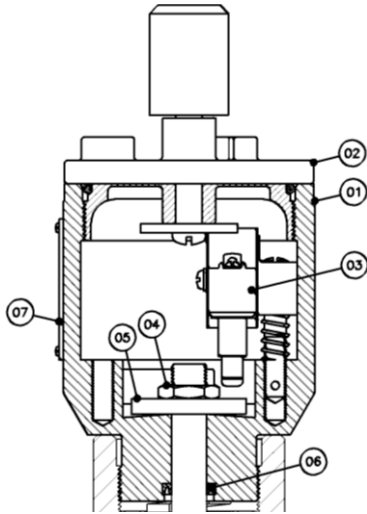

6.9 Type M Switch Housing, Part 340-00191:

Item	Part No.	Description
01	340-00071	Switch Housing
02	340-00116	Manual Housing Cover Assembly
03	340-00050	Variable Microswitch Assembly
04	340-00031	Locknut
05	340-00023	Trip Plate
△ 06	715-10128	Seal Buna-N
07	742-10001	Nameplate
-	340-10166	Grounding Screw
-	340-00032	Drain Screw
-	700-00023	Roll Pin

6.10 Type VV Switch Housing, Part 340-00172:

Item	Part No.	Description
01	340-00071	Switch Housing
02	340-10216	Switch Housing Cover Assembly
03	340-00050	Variable Microswitch Assembly
04	340-00052	Extension Nut
05	340-00023	Trip Plate
△ 06	715-10128	Seal Buna-N
07	340-10165	Dual Tripper Arm Assembly
08	742-10001	Nameplate
-	340-10166	Grounding Screw
-	340-00032	Drain Screw
-	700-00023	Roll Pin

△ Recommended Spare Part

7.0 Warranty

Presco-Switch assemblies have a 12-month warranty on material and workmanship from the time of installation or 18-month from the shipment date, whichever occurs first. Presco-Switch parts have a 12-month warranty from the shipment date. Warranty only applies to the original purchaser of the product. Warranty is non-transferable.

Returns

Pembina Controls must be notified within (5) business days in writing of any suspected defect with the product purchased. Products are to be returned prepaid to the Pembina Controls Manufacturing Center and free of any duties, brokerage, taxes, or other cost. (DDP – Incoterms 2000). Any product returned for warranty consideration will be verified to the satisfaction of Pembina Controls for the alleged defect.

If the product has been in service, it must be cleaned and flushed of any fluids, residue and certified to be free of any hazardous material prior to being returned. An SDS is to be provided for the hazardous materials the switch was in contact with. Product that has not been properly cleaned and without an accompanying SDS will be rejected and returned.

Repair or Replacement

Products that are verified to be defective and are warrantable will be repaired or replaced at the discretion of Pembina Controls. Only the defect is covered and does not include any other portion of the product. Any labour, repair and replacement costs required that are not a direct result of the defect, will be charged to the customer.

Limited Liability

Warranty will be void for any product in respect to and/or as a result of:

- Repair or alteration of any product, portion of the product or parts by parties other than Pembina Controls
- Improper installation, operation, maintenance, repair or service of the product
- Installation of non-OEM parts
- Corrosion or deterioration of product materials due to service conditions or the environment
- Failure to notify Pembina controls in a timely manner of any alleged defect
- Misuse, vandalism, negligence, accidents, acts of God, or other circumstances that are outside the control of Pembina Controls

Warranty is exclusive and in lieu of any other warranties whether direct or implied whatsoever. Any suggestion of suitability to the application shall not be constituted as warranty, unless confirmed as such in writing by Pembina Controls. Liability of Pembina Controls shall in no event exceed the original contract price. Pembina Controls shall not be subject to any and all consequential, incidental and contingent damages whatsoever.



Head Office and Distribution Center:

9511 – 28th Avenue NW | Edmonton, Alberta | T6N 0A3
Phone: 780.432.6821 | Fax: 780.432.6867 | Email: sales@pem-controls.com
Toll Free (USA & Canada): 1.877.736.2462 | International: +01 780.432.6821

All Corporate names and trademarks appearing in this document are the property of their respective entities.
© All rights reserved. 2020 Pembina Controls Inc
