

Model WCM 7300M Temperature Compensated Water Cut Monitor

Bulletin SSIN016 Issue/Rev. 0.1 (11/18)

The **Model WCM 7300M** is designed to provide the highest possible sensitivity, resolution, and accuracy for water content determination in crude oil, other hydrocarbons, or other low dielectric liquids from a max of 25% to levels below 1000 parts per million (ppm). In oil and natural gas (condensate) production, water cut and S&W measurements are significantly improved with the WCM 7300M technology. Enhanced digital signal processing and full product temperature compensation are two of the technological advancements utilized by this device. Probe sizes from 2" through 12" are available. 4-20 mA and 0-5 volt outputs are available for remote readout. Water cut, process temperature or probe electrical value can be selected for viewing without removing conduit cover by use of a supplied magnet to operate an internal reed switch.

Product Temperature Compensation

The base dielectric constant (Dk) of oils can change with changes in temperature. This can cause traditional monitors to change without a variance in water content. For example; for a 10°F change, a typical crude oil may show a reading shift of as much as 0.1%, which normally would be considered as water. The WCM 7300M measures product temperature and calculates a corrected cut reading, providing a true water or S&W cut at any temperature up to 160°F.

Applications

LACT (Lease Automatic Custody Transfer) Units

Detect and provide relay contact closure that can be used to reroute oil that has excess S&W.

Pipeline Loading

Monitor transfer of petroleum/condensate products from loading facilities.

Dehydration Equipment

Determine and enhance equipment efficiencies, by monitoring the product and indicating water content.



Fuel Oil Monitoring

Determine contamination of fuel oil by condensation, or other external factors, before entry to engine.

Storage and Treating Facilities

Monitoring and early detection of undesirable conditions as well as interface detection during dewatering of storage tanks.

Measurement / Monitor Specifications

Power Supply

20-30 Vdc +/-10% @ nominal, 100 mA max.

S&W Full Scale Range

- 0-25%
- Field adjustable to 0-5%, 0-10%, etc.

Accuracy

- Is defined as the variance observed between the 7300M reading and the water grindout of the oil.

Normal variances are:

- +/- .05 from 0 to 5% water
- +/- .1 from 5 to 10% water
- +/- .15 from 10% to 15% water
- +/- .2 to .25 from 15 to 25% water

Displays

One line 16 character, alphanumeric LCD showing by selection:

- Water Cut
- Process Temperature
- Probe Electrical Value

Red/Green LED showing good oil, bad oil, or by passing, condition.

WCM 7300M Dimensions

Inches (mm)

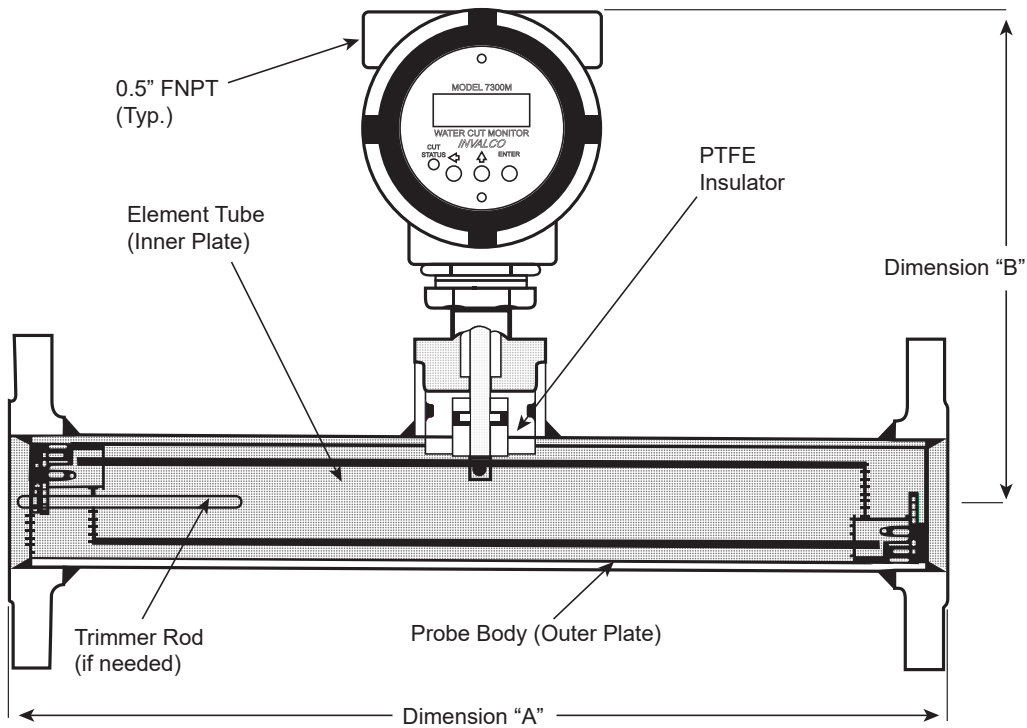

Standard Sizes			
Size	Dim A.	Dim B.	Weight (lb)
2 Inch	17.0" (431)	8.6" (218)	20
3 Inch	32.0" (811)	9.0" (228)	45
4 Inch	32.0" (811)	9.5" (241)	72
6 Inch	32.0" (811)	10.5" (266)	127
8 Inch	32.0" (811)	11.5" (291)	190
10 Inch	32.0" (811)	12.6" (319)	268
12 Inch +	Consult Factory		

Note: Dimensions – Inches to the nearest tenth (millimeters to the nearest whole mm), each independently dimensioned from respective engineering drawings.

Approvals

UL certified Class I Div 1 Groups C & D

WCM 7300M Probe/Monitor Assemblies Ordering Information

WCM 7300M	Water Cut Monitor, Digital, Temperature Compensating, Ranges from 0 - 20% water					
	PROBE MATERIAL: Carbon Steel					
	CODE	PROBE BODY SIZE				
	2	2 INCH I.D. x 17" FACE TO FACE				
	3	3 INCH I.D. x 32" FACE TO FACE				
	4	4 INCH I.D. x 32" FACE TO FACE				
	6	6 INCH I.D. x 32" FACE TO FACE				
	8	8 INCH I.D. x 32" FACE TO FACE				
		CODE	SCREWED ENDS			
		00	SCREWED ENDS (to 3" only)			
		00	GROOVED ENDS / victaulic (to 3" only)			
		00	150 LB ANSI RAISED FACE			
		30	300 LB ANSI RAISED FACE			
		60	600 LB ANSI RAISED FACE (SCH 80)			
		90	900 LB ANSI RTJ			
		05	150 LB ANSI RTJ			
		35	300 LB ANSI RTJ			
		65	600 LB ANSI RTJ (SCH 80)			
		95	900 LB ANSI RTJ (SCH 80)			
		115	1500 LB ANSI RTJ (SCH 80)			
			CODE	MATERIAL AND TEMPERATURE OPTIONS		
			B	STANDARD MATERIALS, A53B CARBON STEEL, 0-160° F		
			H	STANDARD MATERIALS/HIGH TEMP, C/F		
			S	316 STAINLESS STEEL MATERIALS, 0-160° F		
			T	316 STAINLESS STEEL/HIGH TEMP, C/F		
				CODE	CONNECTION STYLE	
				S	SCREWED CONNECTIONS, MNPT	
				G	VICTAULIC CONNECTIONS (GROOVED)	
				F	FLANGED CONNECTIONS	
					CODE	OPEN
					P	EPOXY
Example:						
WCM 7300M -	4	60 -	B	F	P	= WCM 730 - 460 - BFP

Choose one code selection from each option group to build model number.

Revisions included in SSIN016 Issue/Rev. 0.1 (11/18): Approvals section added.

The specifications contained herein are subject to change without notice and any user of said specifications should verify from the manufacturer that the specifications are currently in effect. Otherwise, the manufacturer assumes no responsibility for the use of specifications which may have been changed and are no longer in effect.



TechnipFMC.com

© TechnipFMC 2018. All rights reserved. SSIN016 Issue/Rev. 0.1 (11/18)

TechnipFMC
FMC Technologies, Inc.
13460 Lockwood Rd.
Building S01
Houston, Texas 77044 USA
P:+1 281.591.4200

USA Operation
1602 Wagner Avenue
Erie, Pennsylvania 16510 USA
P:+1 814.898.5000

Germany Operation
Smith Meter GmbH
Regentstrasse 1
25474 Ellerbek, Germany
P:+49 4101.304.0