

Model 780 Liquid / Liquid Interface Measurement System

Bulletin SSIN005 Issue/Rev. 0.1 (8/17)

Interface Measurement System

The superior design of the **INVALCO Interface Measurement System** offers reliable, precise control of gas/liquid or liquid/liquid interface levels. Carefully matched electronic assemblies with probe components combine to provide a measurement system for the most demanding applications. A wide variety of standard features and ease of installation give the Interface Measurement System (IMS) 780 the flexibility necessary for optimum performance. The (IMS) has been carefully designed for dedicated interface control and surpasses all other multi-purpose devices.



Features

- **Excellent sensitivity and repeatability** means precision control even with difficult applications.
- **Non-fouling probe** for continuous, reliable use.
- **Convenient operator interface** provides visual status indication and greatly reduced set-up time.
- **Individually adjustable dual outputs with time delay** allows the flexibility needed to change and customize control of your system.
- **Approved for use in hazardous locations, cUL and UL approved.** Class 1 Groups C & D.
- **110/220 VAC or 24 VDC 6 watts**
- **Probe length variations available. Consult factory.**

Theory of Operation

The INVALCO IMS Model 780 works on the principle of measuring an electrical value, called capacitance, that exists from its probe to ground. It does this by measuring the dielectric constant (dk) value of the material surrounding the probe and the distance from the probe to the nearest, and largest, ground plane which normally is the conductive water below the oil/water interface. The capacitance value

will increase if the material dk increases, or if the water moves closer to the probe. Conversely, the capacitance will decrease if the material dk decreases, or if the water moves away from the probe. The main, dominating, factor is the distance from the probe to the water which thereby allows the IMS 780 to be a superior level indicator/control device. The unit is sensitive to extremely small changes (± 0.3 pf) and with a horizontally mounted probe, can be set to measure a clean interface as much as 24 inches away, depending upon fluid characteristics.

The use of capacitance to detect interface levels in many applications has always been complicated by the electrical conductivity of the fluids and the buildup of conductive materials on the probes. These cause changes in conductivity which are mistaken for changes in capacitance, resulting in a misinterpretation of the interface level, or instrument failure. Interference caused by changes in conductivity are virtually eliminated by the use of high frequencies in the INVALCO IMS detection circuit design. Normally, high frequency requires the use of special cable (coaxial) to carry the signal which introduces other complications. The high frequency oscillator and detection circuitry in the INVALCO IMS are mounted in the probe and overcome the need for special cable. The control unit can be remotely mounted up to 500 feet away.

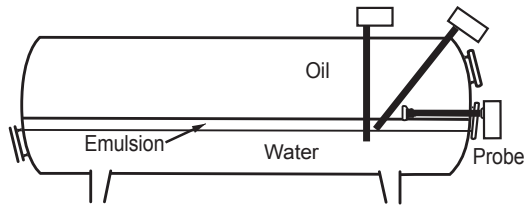

Figure 1. Various Probe Locations

Applications

Petroleum and Gas

- Separators
- Heater Treaters
- Desalters
- Free-water Knock-out

Other Industrial Liquid Processing

- Storage Tanks
- Extraction Units
- Separation Equipment

IMS Model 780

The Model 780 is designed to provide both a continuous (throttling) and snap-acting (on/off) output mode.

The snap-acting selector is a 10-position switch. The zero position is normally used when the Model 780 is used to detect a gas/liquid interface. Positions 1-9 are used to detect ever-increasing concentrations of water-in-oil. Position 1 is nearest 100% oil, position 9 is nearest 100% water.

The Model 780 is also capable of developing a 4-20 mA throttling output which is particularly effective when applied to free-water knock-outs, treaters (crude oil dehydrators), wash tanks (gun barrels), skim tanks, three-phase separators, and other process vessels where an interface level must be maintained at a reasonable constant level.

The throttling selector has four positions marked 1, 2, 3, and 4. These positions correspond with the instruments overall span with respect to the water content of the oil at the interface.

Though actual water concentrations corresponding to the four positions vary with the different characteristics of oil and water, the general ranges follow:

General Ranges	
Position 1	0 - 25% Water
Position 2	0 - 50% Water
Position 3	0 - 75% Water
Position 4	0 - 100% Water

Installation and Start-up

The Model 780 probe may be installed horizontally, vertically, or at an angle. A horizontal mounted probe will be able to detect an interface further away than a vertical or

angle mounted probe due to the area of the probe, which is parallel to the interface. A horizontally mounted probe will have the entire length and width of the probe's electrode parallel to and "looking down" on the interface while a vertical, or angle mounted probe will have only the circular area of the end of the probe electrode "looking down" on the lower interface.

Normally a horizontally mounted probe is used when it is desired to control an interface below the probe while a vertical or angle mounted probe is used when it is desired to control the interface on the probe electrode proper.

A packing gland on the probe allows it to be installed into, or removed from, a vessel without having to depressurize, or drain down, the vessel.

A single screwdriver calibration potentiometer is adjusted to set up the instrument for level control or interface control. Then simply turn the two knobs on the face of the 780 to get the desired relay and 4-20mA outputs. Then turn the time delay knob to eliminate any relay chatter caused by ripples, or waves, on the interface surface.

Specifications

Operating Temperature	-20°F to 160°F
Probe Temperature	250°F Maximum
Power	110/220 VAC, 50/60 Hz or 24 VDC 6 watts
Maximum Working Pressure	350 psig @ 100°F
Outputs	<ul style="list-style-type: none"> • Continuous - 4 to 20 mA • Relay Contacts - DPDT, 10 Amps at 115 VAC non-inductive
Fail-safe Mode	Low Level
Sensitivity	+/- 0.3 pf
Response Time to a dk Change	0.75 seconds or less.
Enclosures	<ul style="list-style-type: none"> • Weatherproof - NEMA 4X • Explosion-proof - Class 1, Groups C and D.
Adjustable Time Delay For Relay Closure	0-55 Seconds
Certification for Use in Hazardous Areas	<p>Probe is certified for use with either W.P. or X.P. housed control unit. X.P. housed control unit is certified for use in hazardous areas.</p> <ul style="list-style-type: none"> • cUL and UL approved • File: E215164 • Type: Class 1, Groups C & D

Probe Mounting on Vessel Wall Through a 1" NPT Ball Valve

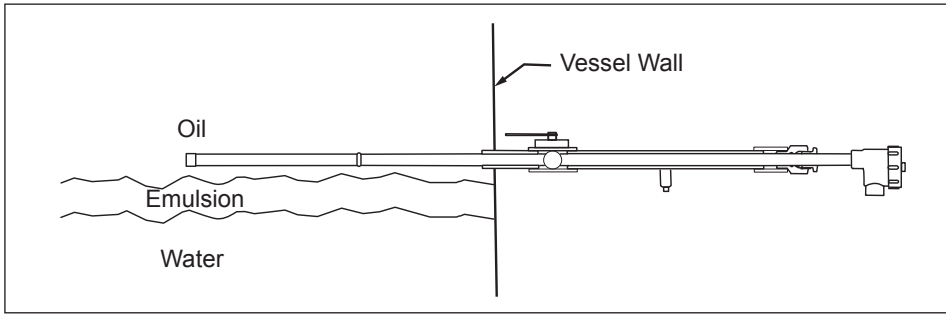

Model 780 Interface Measurement System

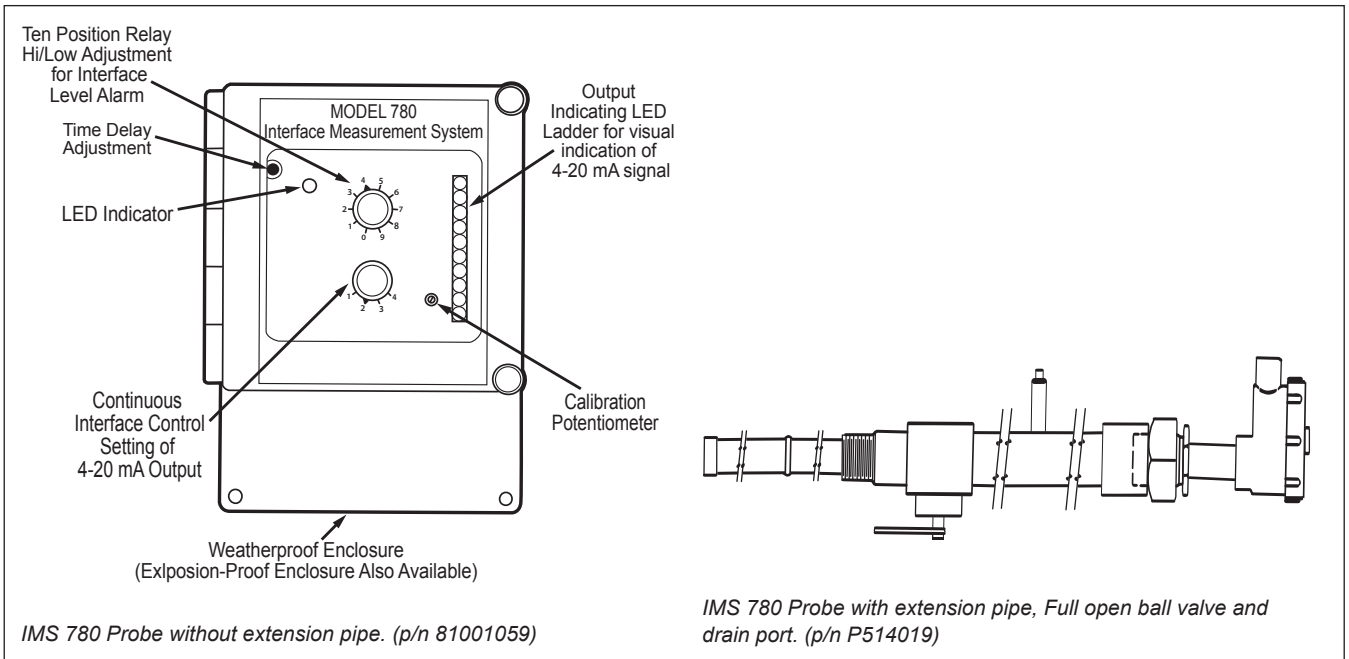

Dimensions - Inches (mm)

Dimensions — Inches to the nearest tenth (millimeters to the nearest whole mm), each independently dimensioned from engineering drawings.

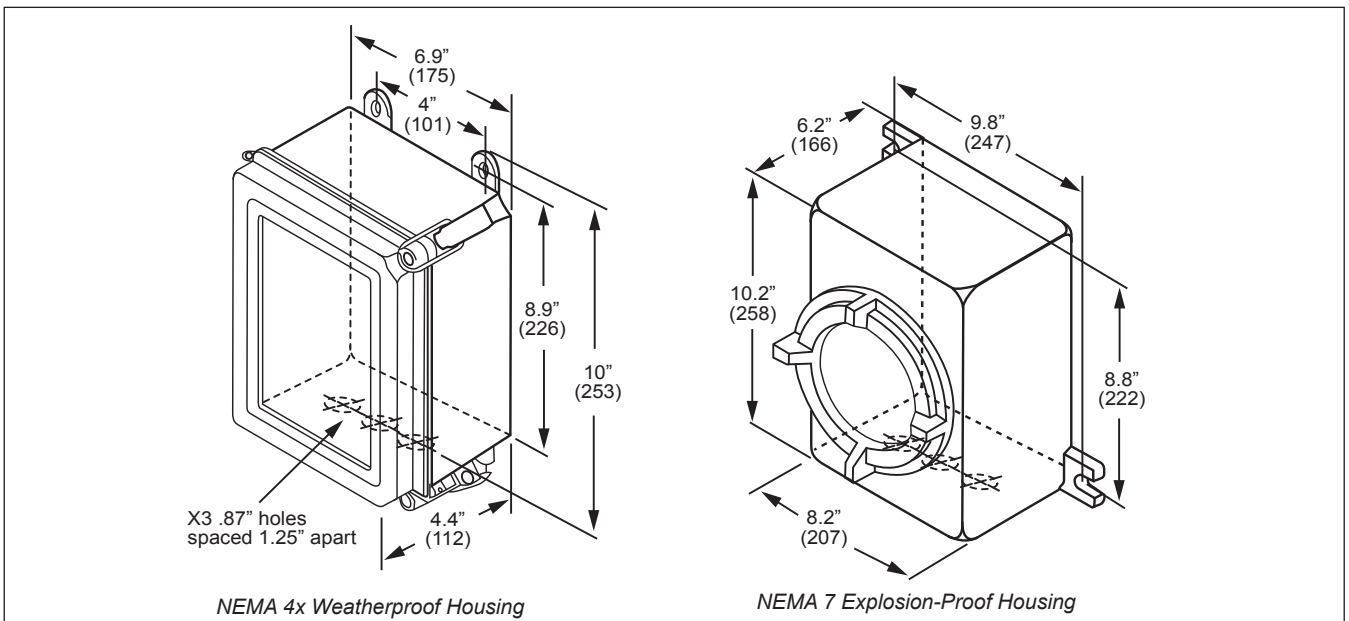

System with Probe without Extension Pipe Assembly

Model Number	110V AC 50/60 Hz	Part Number
Model 780-XP	Interface Measurement System - Explosion-proof - NEMA 7, w/Probe and 20 ft. of Cable	81001055
Model 780-WP	Interface Measurement System - Weatherproof - NEMA 4X, w/Probe and 20 ft. of Cable	81001057
	Probe Assembly c/w PC701 Detector Card	81001059
Model Number	220VAC 50/60 Hz	Part Number
Model 780-XP	Interface Measurement System - Explosion-proof - NEMA 7, w/Probe and 20 ft. of Cable	81001052
Model 780-WP	Interface Measurement System - Weatherproof - NEMA 4X, w/Probe and 20 ft. of Cable	81001053
	Probe Assembly c/w PC701 Detector Card	81001059
Model Number	24 VDC	Part Number
Model 780-XP	Interface Measurement System - Explosion-proof - NEMA 7, w/Probe and 20 ft. of Cable	81001054
Model 780-WP	Interface Measurement System - Weatherproof - NEMA 4X, w/Probe and 20 ft. of Cable	81001152
	Probe Assembly c/w PC701 Detector Card	81001059
Chassis	110 VAC 50/60 Hz includes Relay LED Ladder	81001050
Chassis	220 VAC 50/60 Hz includes Relay LED Ladder	81001049
Chassis	24 VDC includes Relay LED Ladder	81001151
Probe	Std. Probe Only, No Detector Card, No Extension Pipe	81001060
Detector	PC701 Detector Card Fits All Probes	49020038

System with Probe with Extension Pipe Assembly

Model Number	110 VAC 50/60 Hz	Part Number
Model 780-XP-E	Interface Measurement System - X.P. NEMA 7 w /Probe with Ext. Pipe, Valve, 20' Cable	P514037
Model 780-WP-E	Interface Measurement System - Weatherproof - NEMA 4X, w /Probe and 20 ft. of Cable	P514987
	Probe Assembly c/w extension pipe, valve, drain, and PC701 Detector Card	P514019

Notes: Probe P/N P514019

The extension pipe is one inch, complete with a full opening one inch ball valve (for isolation purposes) and a 1/4" drain with plug.

The probe used with the extension pipe has two welded on safety rings, one on each end, to preclude the expulsion of the probe by pressure.

The probe is removed from the vessel by loosening the packing nut behind the mounting hub and pulling the probe out until the front safety ring hits the forward end of the mounting hub. The ball valve is then closed and the drain opened. After pressure is released, and fluid drained out, the mounting hub is unscrewed from the collar on the extension pipe allowing the probe to be removed.

The specifications contained herein are subject to change without notice and any user of said specifications should verify from the manufacturer that the specifications are currently in effect. Otherwise, the manufacturer assumes no responsibility for the use of specifications which may have been changed and are no longer in effect.

Contact information is subject to change. For the most current contact information, visit our website at www.fmctechnologies.com/measurementsolutions and click on the "Contact Us" link in the left-hand column.

TechnipFMC.com

FMCTechnologies.com/MeasurementSolutions

© TechnipFMC 2017 SSIN005 Issue/Rev. 0.1 (8/17)

TechnipFMC
FMC Technologies
Measurement Solutions, Inc.
500 North Sam Houston Parkway West,
Suite 100
Houston, Texas 77067 USA
P:+1 281.260.2190

USA Operation
1602 Wagner Avenue
Erie, Pennsylvania 16510 USA
P:+1 814.898.5000

Germany Operation
Smith Meter GmbH
Regentstrasse 1
25474 Ellerbek, Germany
P:+49 4101.304.0